

9 8 7 6 5 4 3 2 1

- NOTES:
- BOX SIZE (APPROX.):
    - WIDTH: ~ 35 INCH ( 889 mm)
    - LENGTH: ~ 88 INCH ( 2235 mm)
    - HEIGHT: ~ 29.5 INCH ( 750 mm)
  - BOXED UNIT GROSS WEIGHT: 569 LBS (258 Kg)
  - TREADMILL NET WEIGHT: 510 LBS (232 Kg)
  - BOX LABELS (4) WITH THE FOLLOWING INFORMATION:
    - MODEL: BASE, UNIV, 9-9271, 10-TRx, 110V 18A, UL/CSA/FCC
    - SKU: 9-9271-XXXXP0 ("XXXX" SPECIFIED IN P.O.)
    - SERIAL NUMBER: PER DOC 622-200-110
    - BAR CODE: CODE 128
  - PRIMARY SERIAL LABEL INFORMATION:
    - SKU: 9-9271-XXXXP0 ("XXXX" SPECIFIED IN P.O.)
    - SERIAL NUMBER: PER DOC 622-200-110
    - MFG DATE: MM/YYYY
    - PHASE: SINGLE
    - CYCLES: 50/60
    - WATTS: 1980
    - VOLT/AMPS: 110/18
    - TYPE: IPX0
    - CERTIFICATIONS: UL/CSA/FCC
  - SECONDARY SERIAL LABEL INFORMATION:
    - SKU: 9-9271-XXXXP0 ("XXXX" SPECIFIED IN P.O.)
    - SERIAL NUMBER: PER DOC 622-200-110
  - COLOR PER -XX DESIGNATED IN PARENT SKU, -XX COLOR PER SOP 622-200-112

REVISION HISTORY				
REV	DATE	DESCRIPTION	ECO	BY
024	6/5/2019	REMOVE 050-5589 (2) 715-4279-XX (2); ADD 715-4330-XX (2)	---	SCN
A	6/6/2019	PRODUCTION RELEASE	15893	KD
B	3/18/2020	UPDATE RED COMPONENTS TO STAR TRAC RED: LAB TARGET NUMBER L: 32 A: 66 B: 44 (CORE -XX COLOR -99) ADD NOTES/REF COLUMN TO BOM	20025	MMG

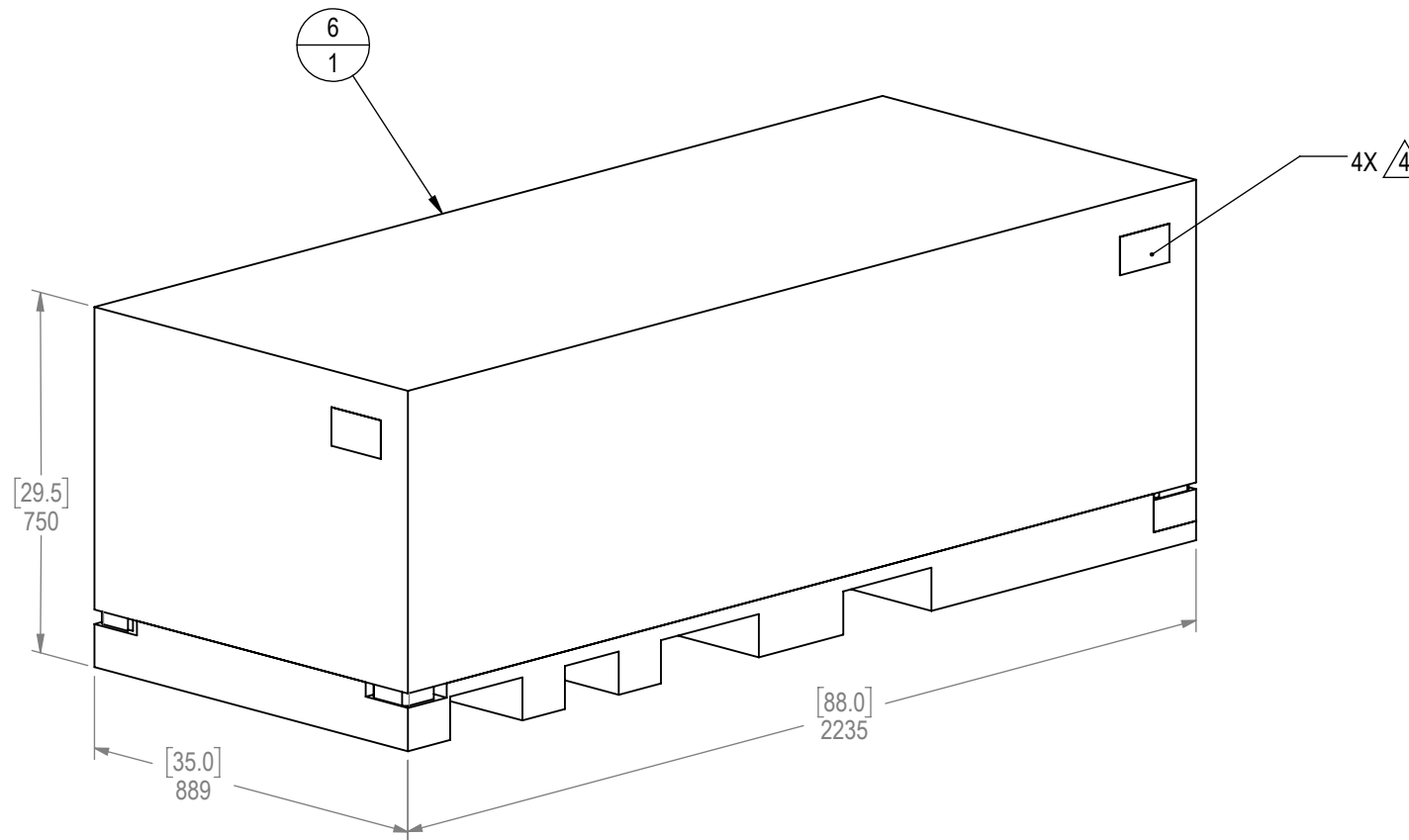

**DOCUMENT STATUS:**

NOTICE OF PROPRIETARY INFORMATION  
THIS DOCUMENT SHALL NOT BE REPRODUCED NOR SHALL THE INFORMATION CONTAINED HEREIN BE USED BY OR DISCLOSED TO OTHER EXCEPT AS EXPRESSLY AUTHORIZED BY CORE HEALTH & FITNESS, LLC.

MATERIAL SEE BOM	THIRD ANGLE PROJECTION			CORE HEALTH & FITNESS, LLC 4400 NE 77th Ave., Suite 300 Vancouver, WA 98662		
				CORE PART NO	REV	
FINISH N/A	DRAWN	INITIAL SCN	DATE 5/10/2018	<b>9-9271-XXXXP0</b>	<b>B</b>	TITLE BASE, UNIV, 9-9271, 10-TRx, 110V 18A, UL/CSA/FCC
VENDOR: N/A	P/N: N/A	U.O.M.	MM	SCALE: 1:15	SHEET 1 OF 4	SHEET SIZE: B

9 8 7 6 5 4 3 2 1

\*REFERENCED ITEMS ARE CONTAINED IN HARDWARE PACK 715-4318-XX 

ITEM NO.	PART NUMBER	DESCRIPTION	QTY.	NOTES*
1	020-7853-XX	RAIL, UPRIGHT, FLEXDECK, LEFT	1	
2	020-7854-XX	RAIL, UPRIGHT, FLEXDECK, RIGHT	1	
3	020-7911-XX	BEAUTY-RING, HANDRAILS, 150X50	2	REF
4	050-2199	LABEL, SECONDARY S/N, CARDIO	1	
5	050-5456	Label, S/N, Powered, Primary, Core H&F	1	
6	050-5632	ASSY, KIT, PACKAGING, 10-TRx	1	
7	110-3522	SCREW, M5x0.8, 10mm, PHM, PH, SS	6	
8	<del>110-3561</del>	SCREW, M5x0.8, 16mm, PHM, PH, SS, BO	20	REF (8)
9	<del>110-3562</del>	SCREW, M5x0.8, 30mm, PHM, PH, SS, BO	2	REF
10	110-3563	SCREW, M5 X 0.8, 16mm, FHM, PH, SS, BO	4	
11	110-3704	SCREW, M5x0.8, 8mm, PHMS, CS, ECB	8	
12	110-4055	SCREW, M10x1.5, 20mm, HHC, HE, AS, NKL, FL, Gr-10.9	8	REF
13	120-3403	WASHER, 5.3mm ID x 15mm OD x 1.4mm THK, CS, BEC	2	
14	140-3683	GROMMET, RT, HANDRAIL, DECK, FLEX, TREADMILL	4	REF
15	140-3684	GROMMET, LT, HANDRAIL, DECK, FLEX, TREADMILL	4	REF
16	<del>220-0278</del>	LINE CORD, 110V, NEMA 5-20 PLUG	1	
17	620-8682	USER MANUAL, 10-TRx	1	
18	620-8683	MANUAL, INSTALLATION, FREERUNNER, 10-TRx	1	
19	715-4239-XX	ASSY, BASE, DECK, FLEX, TREADMILL	1	
20	715-4240	ASSY, ELEC, 110V, 18A, UL/FCC/CSA, DECK, FLEX	1	
21	715-4249-XX	ASSY, STEP, LT, DECK, FLEX, TREADMILL	1	
22	715-4254-XX	ASSY, HANDRAIL, W/HB, DECK, FLEX, TREADMILL	1	
23	715-4257-XX	SHROUD, MOTOR, DECK, FLEX, TREADMILL	1	
24	715-4259-XX	SHROUD, ENDCAP, INNER, LR, DECK, FLEX, TREADMILL	1	
25	715-4260-XX	SHROUD, ENDCAP, TOP, RR, DECK, FLEX, TREADMILL	1	
26	715-4263-XX	SHROUD, ENDCAP, INNER, RR, DECK, FLEX, TREADMILL	1	
27	715-4264-XX	SHROUD, ENDCAP, TOP, LR, DECK, FLEX, TREADMILL	1	
28	715-4265-XX	SHROUD, CTR, FRONT, DECK, FLEX, TREADMILL	1	
29	715-4267-XX	SHROUD, LT, FRONT, DECK, FLEX, TREADMILL	1	
30	715-4268-XX	SHROUD, RT, FRONT, DECK, FLEX, TREADMILL	1	
31	715-4270-XX	ASSY, STEP, RT, DECK, FLEX, TREADMILL	1	
32	715-4318-XX	KIT, HARDWARE, FLEX, TREADMILL	1	
33	715-4319-XX	ASSY, SHROUD, ENDCAP, OUTER, RR, FLEX, TREADMILL	1	
34	715-4320-XX	ASSY, SHROUD, ENDCAP, OUTER, LR, FLEX, TREADMILL	1	
35	715-4330-XX	ST LOGO, W/, SHROUD, BUMPER, DECK, FLEX, TREADMILL	2	

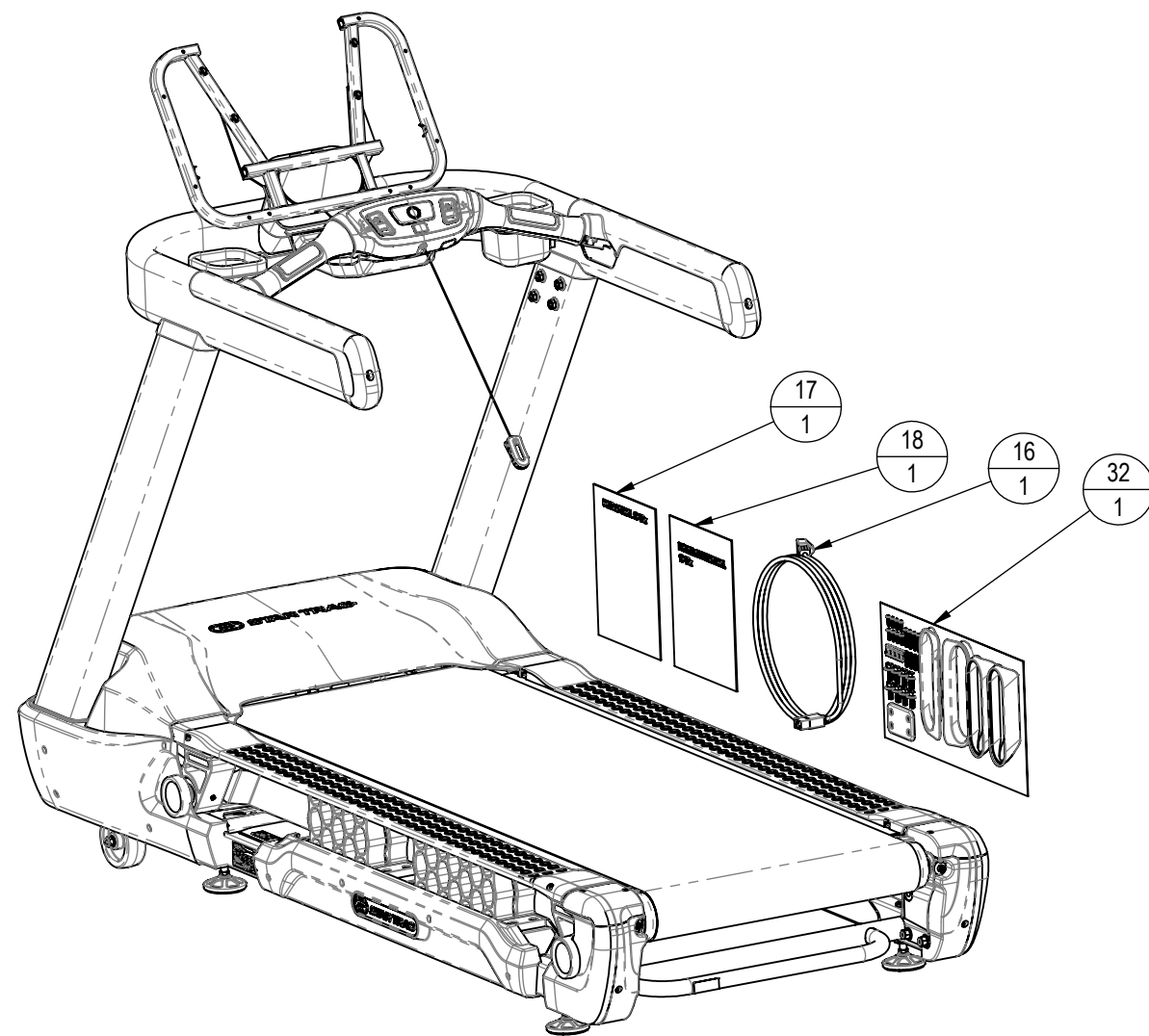

**CORE HEALTH & FITNESS, LLC**  
 4400 NE 77th Ave., Suite 300  
 Vancouver, WA 98662

CORE PART NO	<b>9-9271-XXXXP0</b>	REV	<b>B</b>
TITLE	BASE, UNIV, 9-9271, 10-TRx, 110V 18A, UL/CSA/FCC		
SCALE:	1:13	SHEET 2 OF 4	SHEET SIZE: B

NOTES:  
 10. TO PREVENT PLASTIC SHOULDERS FROM CRACKING, DO NOT USE POWER TOOLS TO TIGHTEN PLASTIC SCREWS

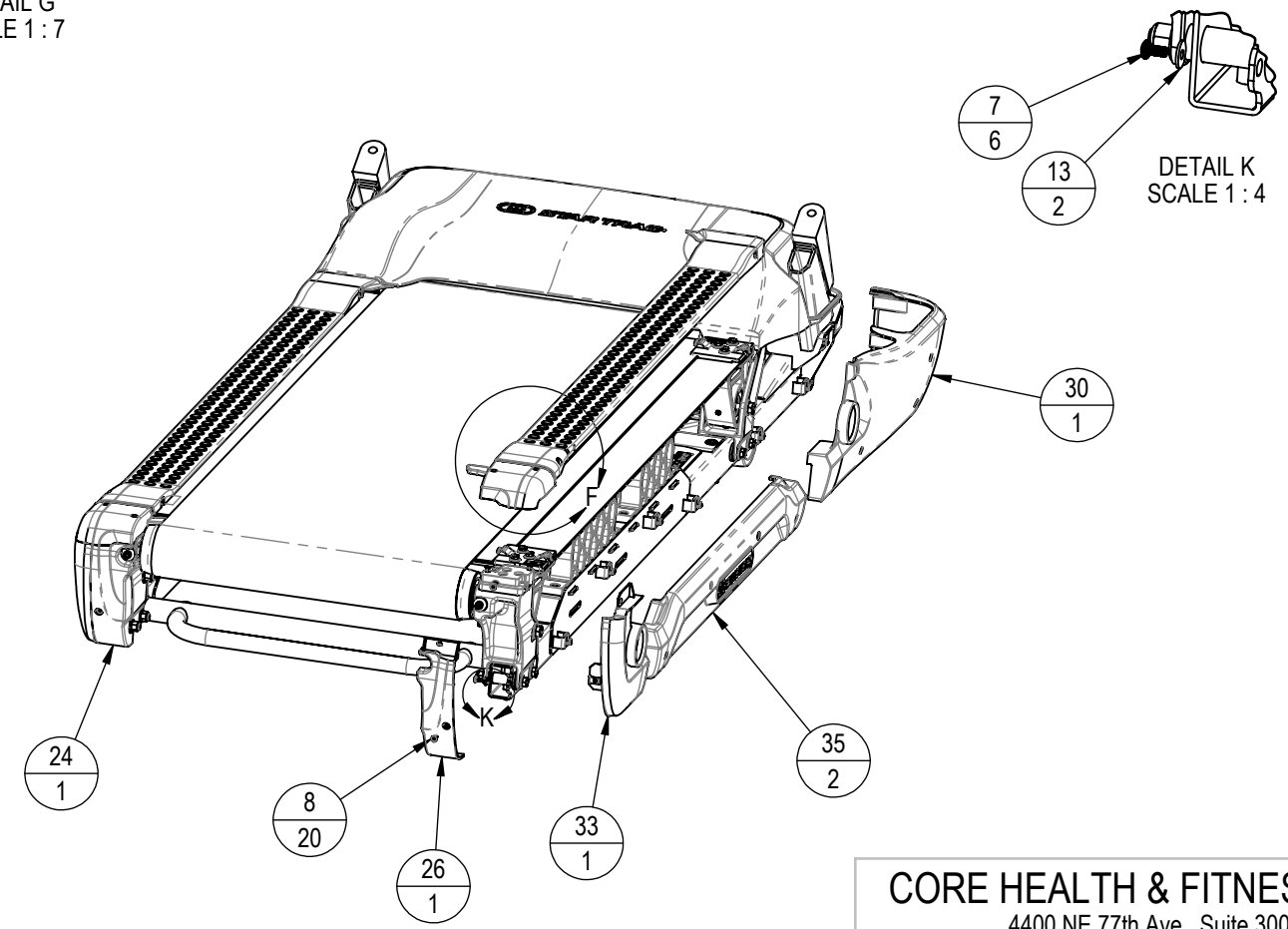
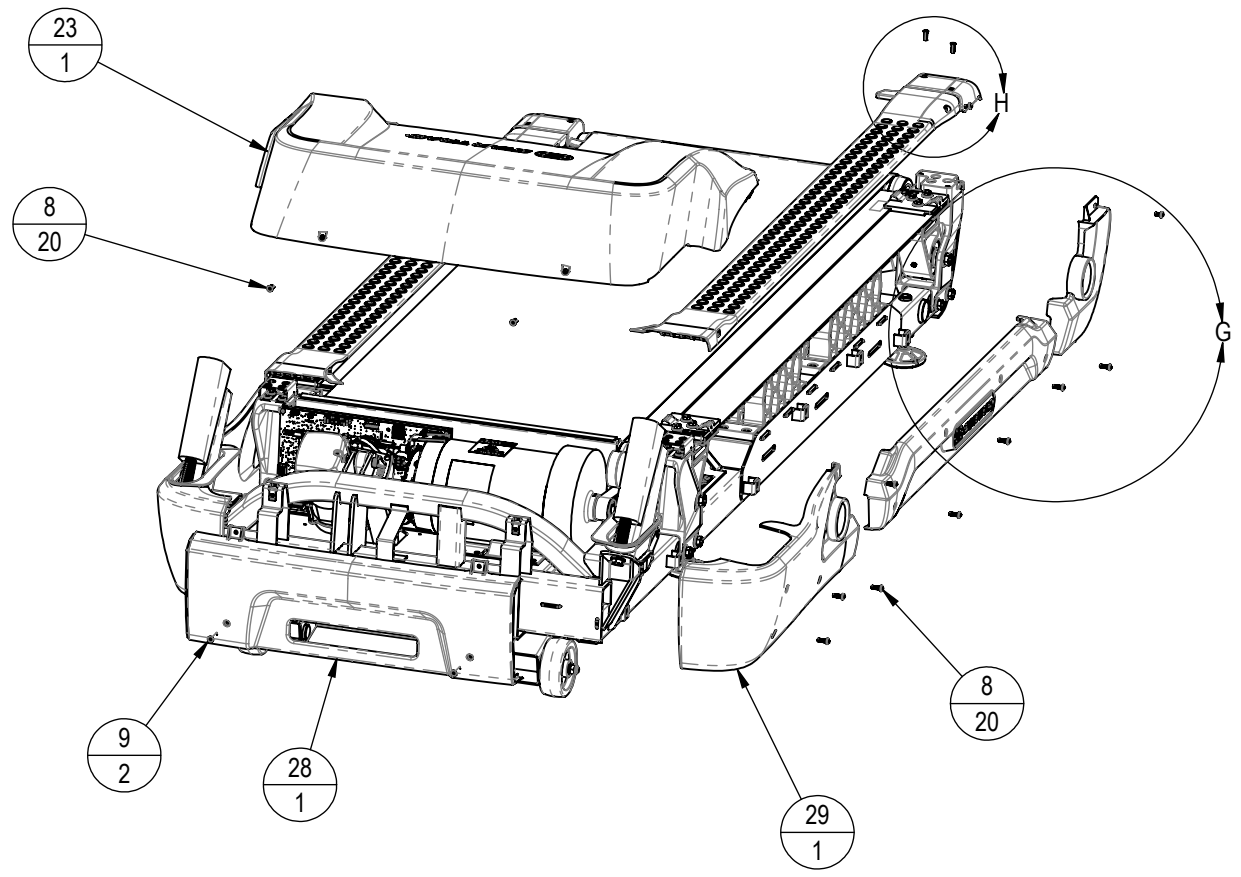
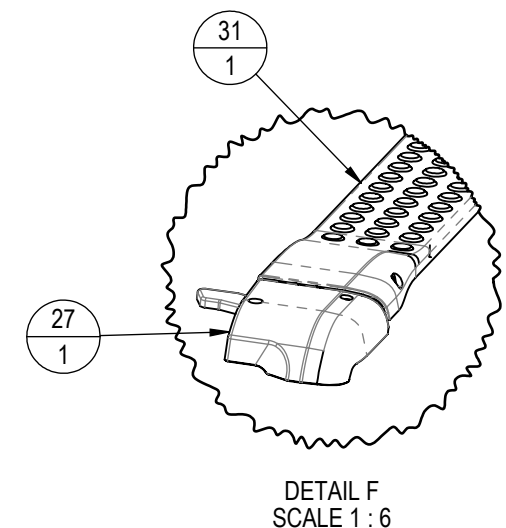
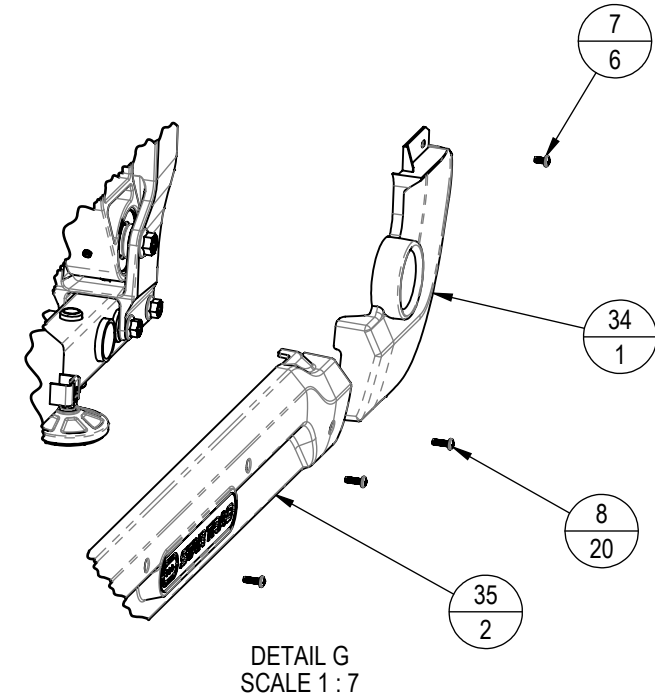
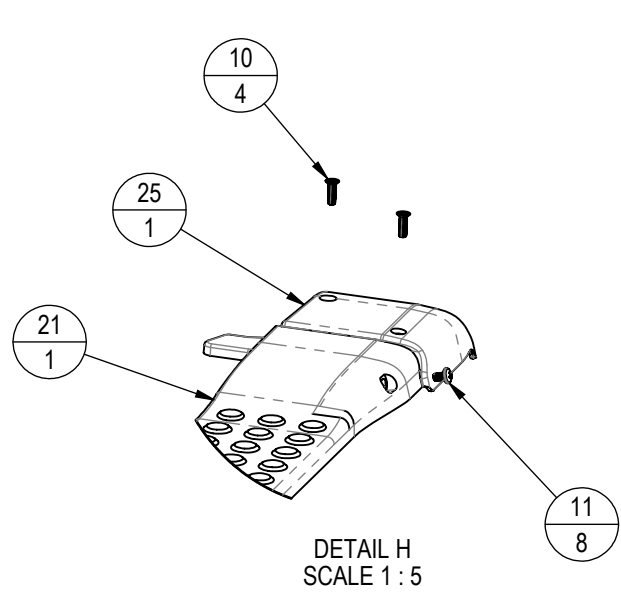

**CORE HEALTH & FITNESS, LLC**  
 4400 NE 77th Ave., Suite 300  
 Vancouver, WA 98662

CORE PART NO	REV
<b>9-9271-XXXXP0</b>	<b>B</b>
TITLE BASE, UNIV, 9-9271, 10-TRx, 110V 18A, UL/CSA/FCC	
SCALE: 1:13	SHEET 3 OF 4   SHEET SIZE: B

9 8 7 6 5 4 3 2 1

NOTES:  
 8. CLEAN SURFACE WITH DENATURED ALCOHOL BEFORE APPLYING DECALS  
 9. TORQUE TO 50 FT-LB (68 N-m)  
 10. TORQUE TO 35 FT-LB (47 N-m)

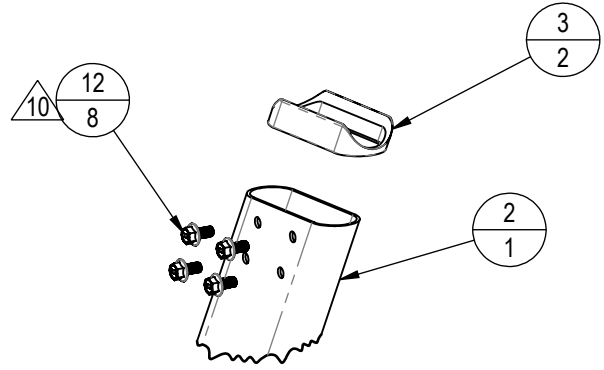
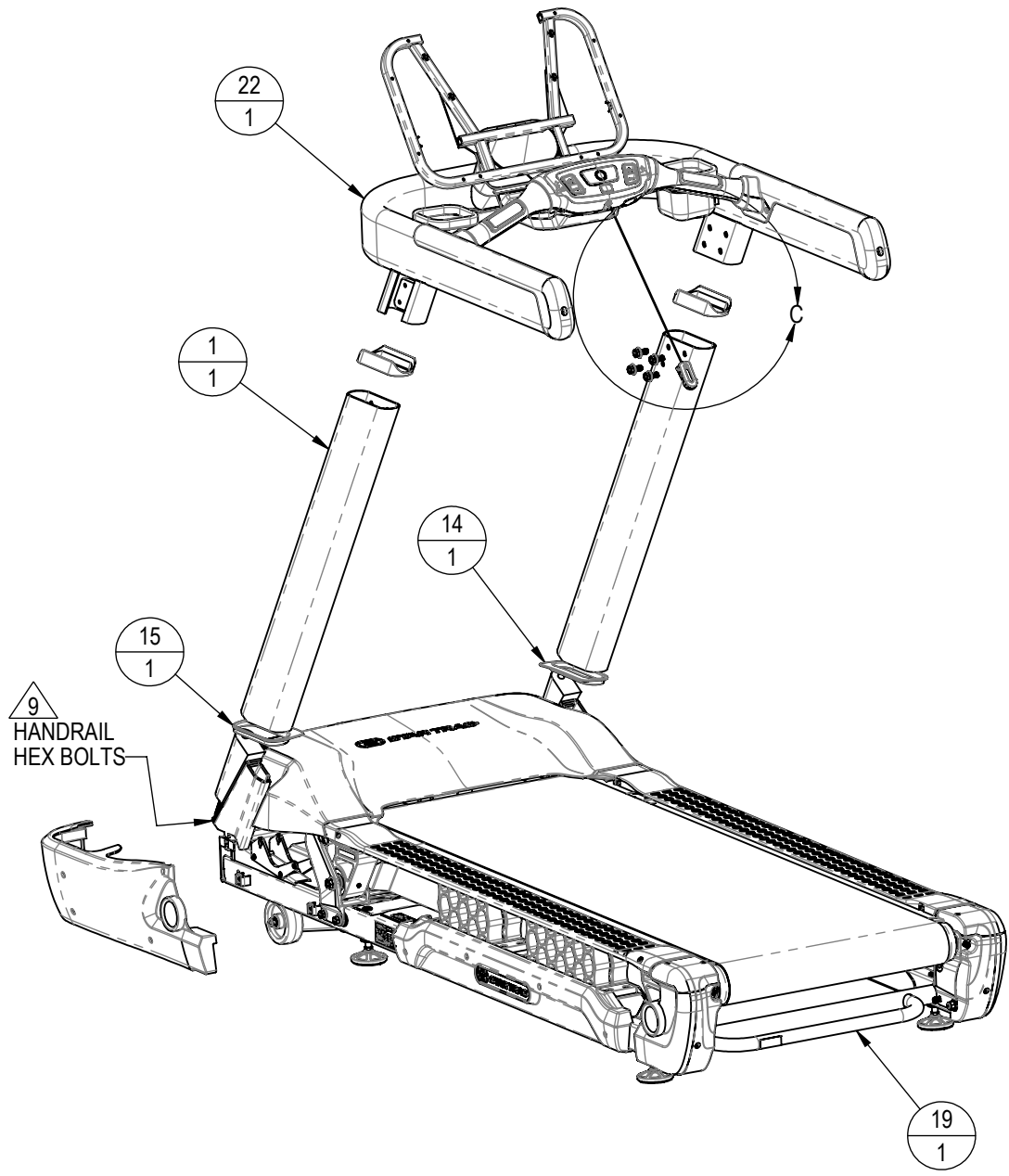

DETAIL C  
SCALE 2 : 15

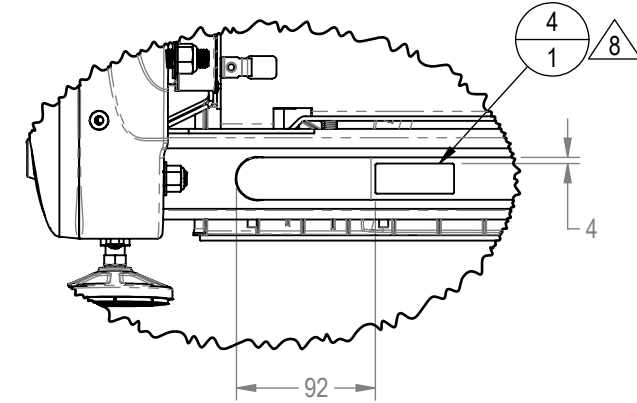
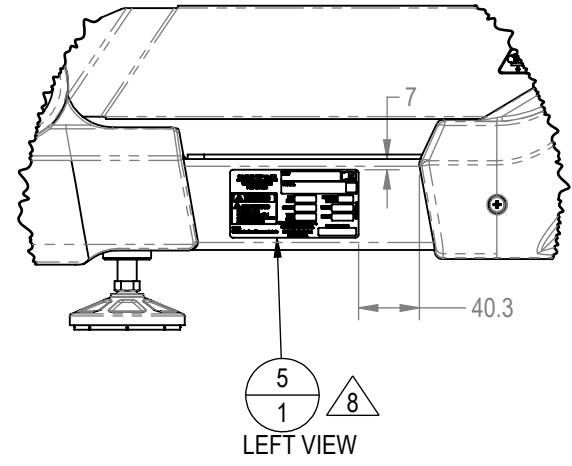

CORE HEALTH & FITNESS, LLC	
4400 NE 77th Ave., Suite 300 Vancouver, WA 98662	
CORE PART NO	REV
<b>9-9271-XXXXP0</b>	<b>B</b>
TITLE BASE, UNIV, 9-9271, 10-TRx, 110V 18A, UL/CSA/FCC	
SCALE: 1:33.3	SHEET 4 OF 4   SHEET SIZE: B

9 8 7 6 5 4 3 2 1